

Top View

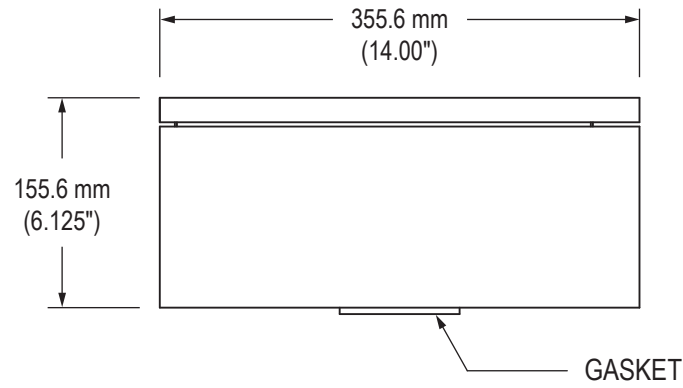

Rear View

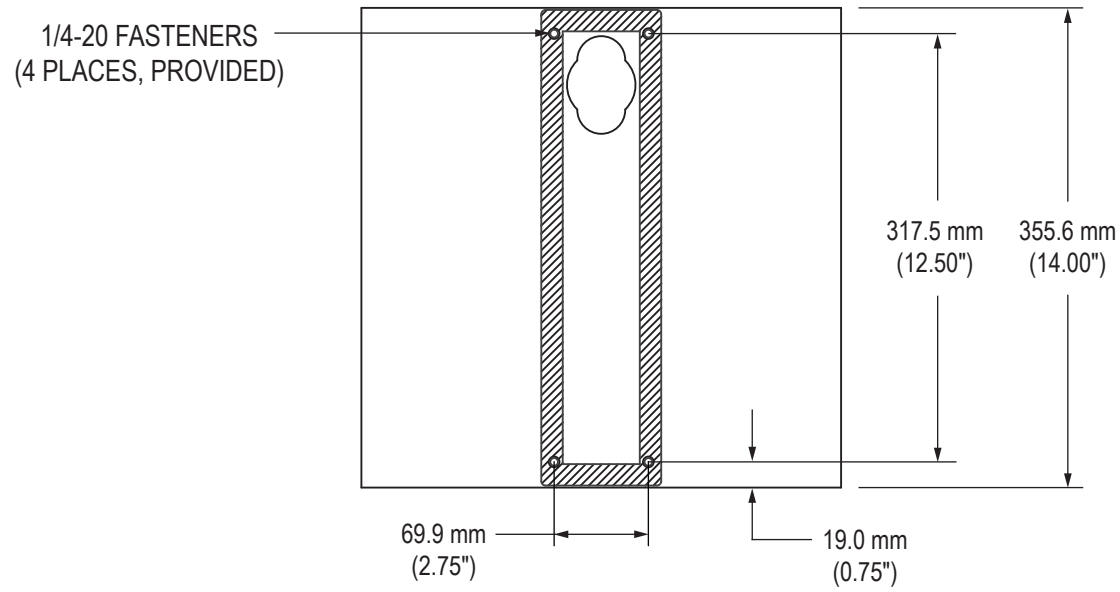

Inside View of Access Door

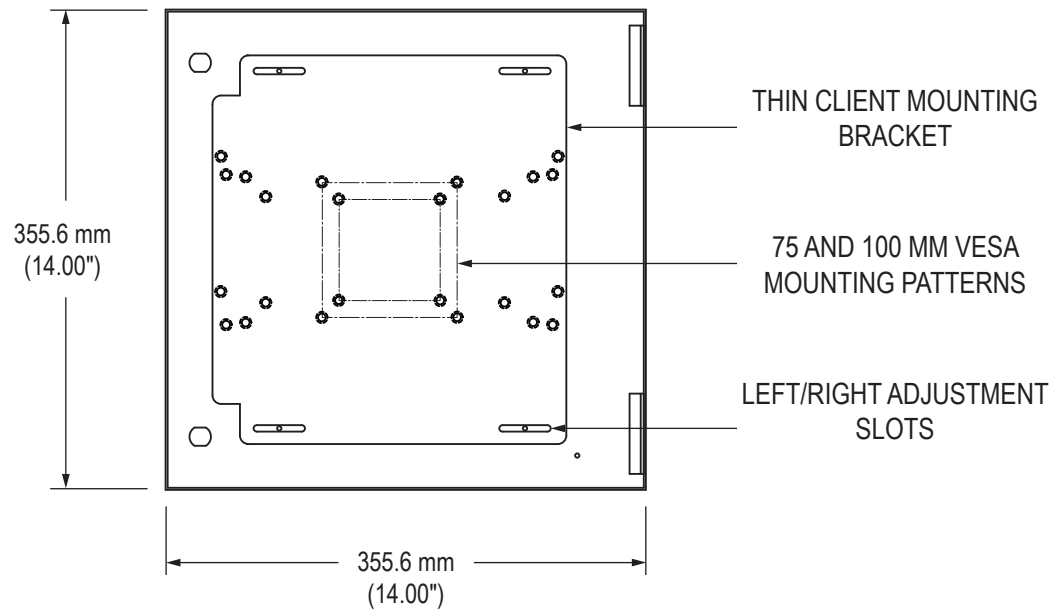

Inside View of Enclosure

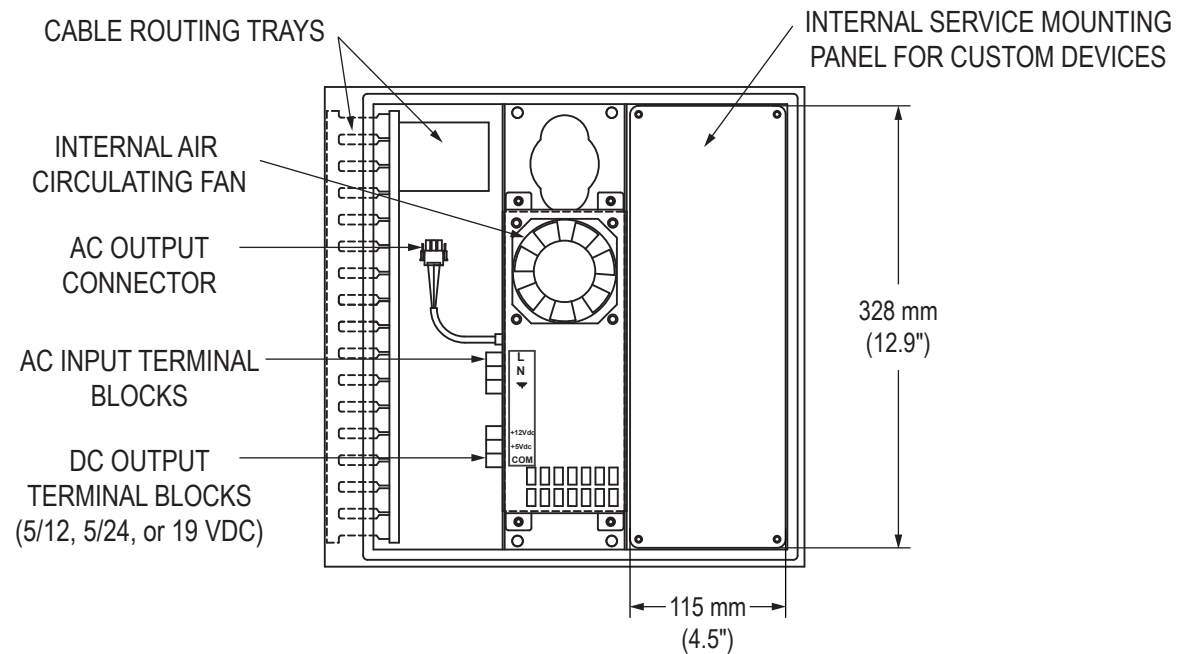

Close-up of Access Door (showing Mounting Bracket measurements)

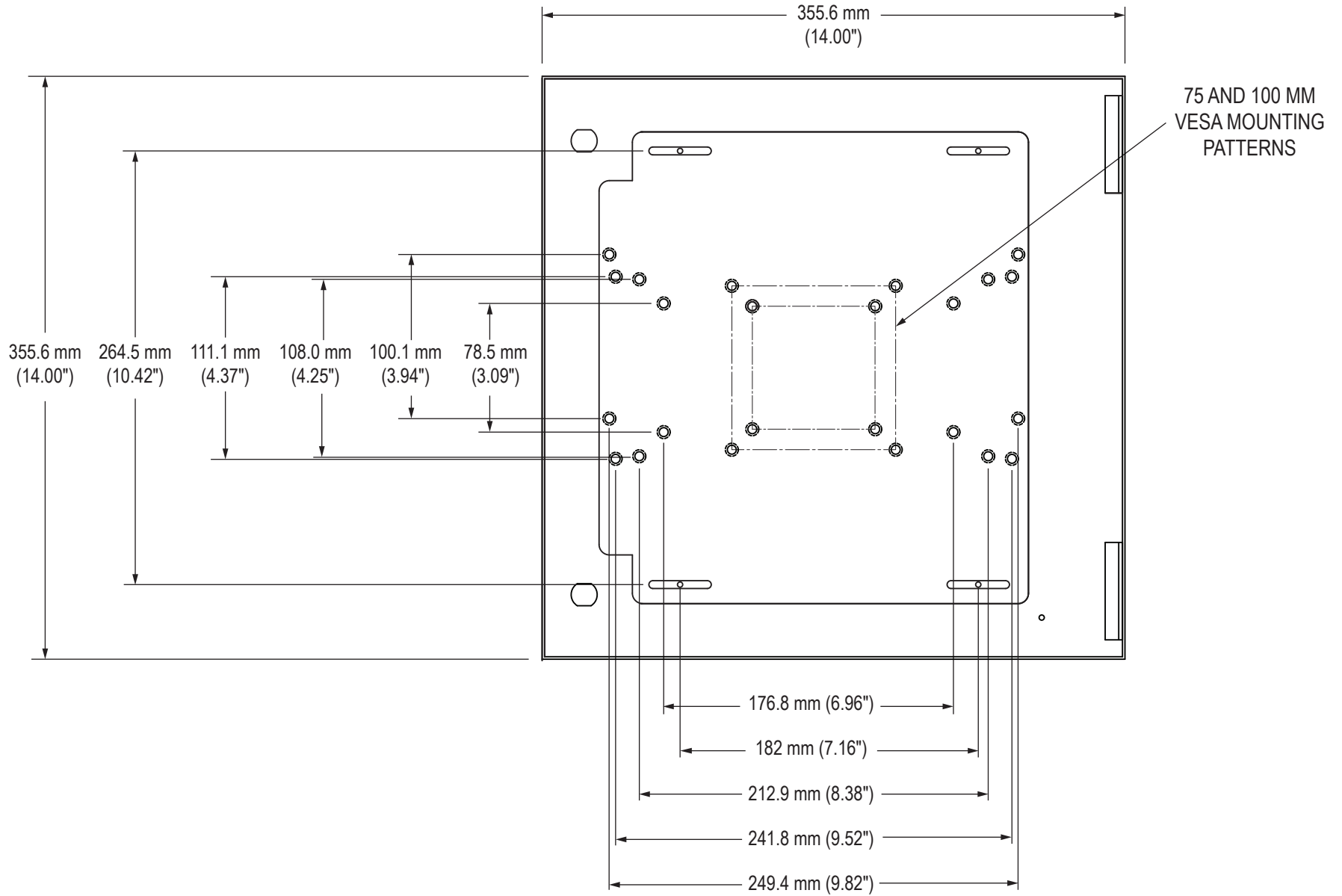

Mechanical Drawing – Thin Client / Small PC Enclosure



WALL MOUNTING BRACKET

Front View of Enclosure

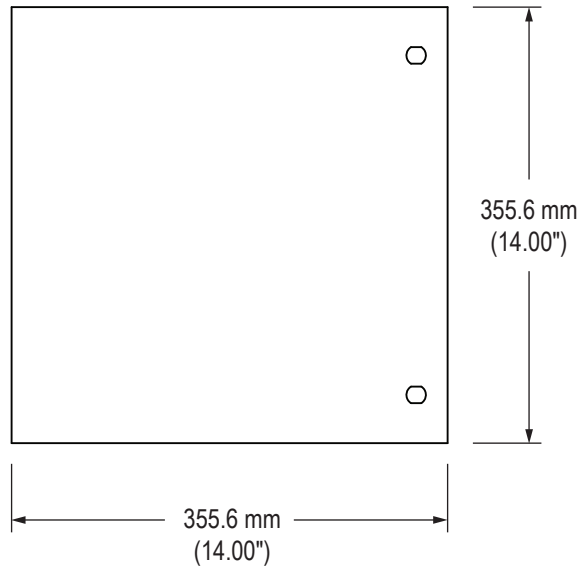

Side View

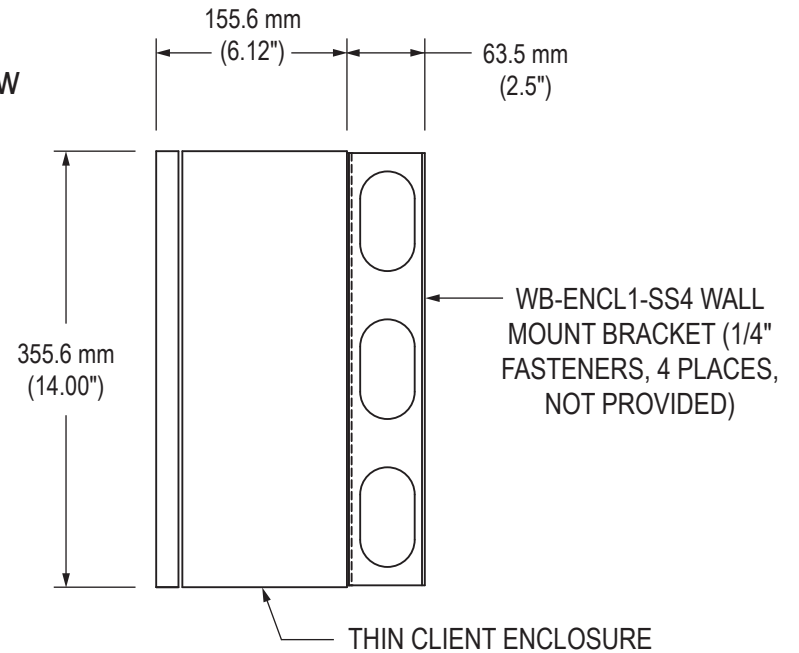

Rear View

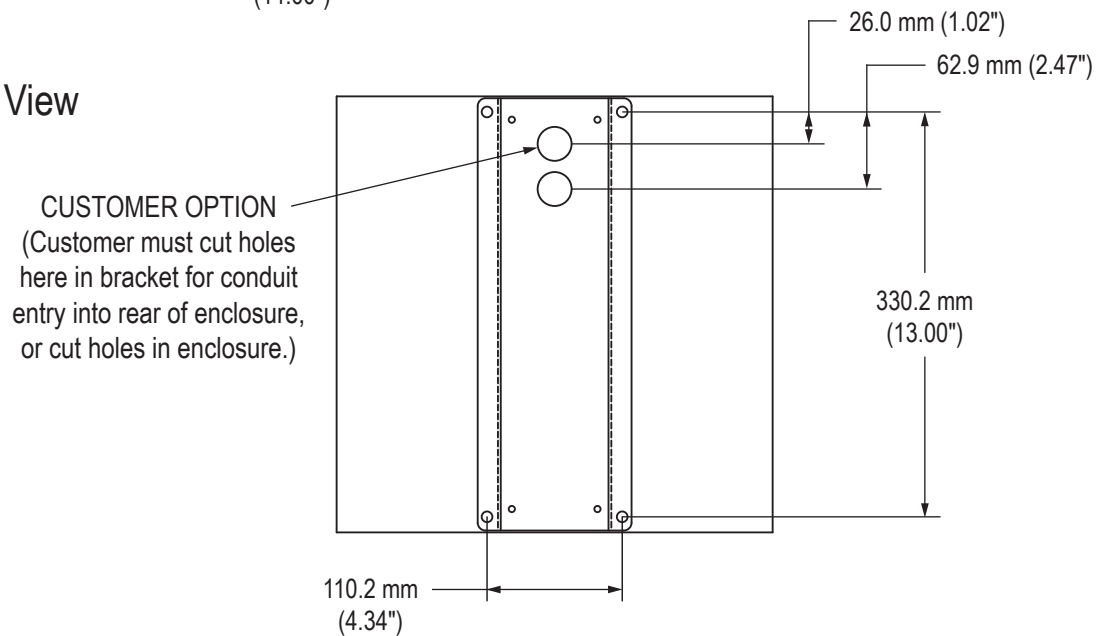

MOUNTED ON PED4X4

Rear View

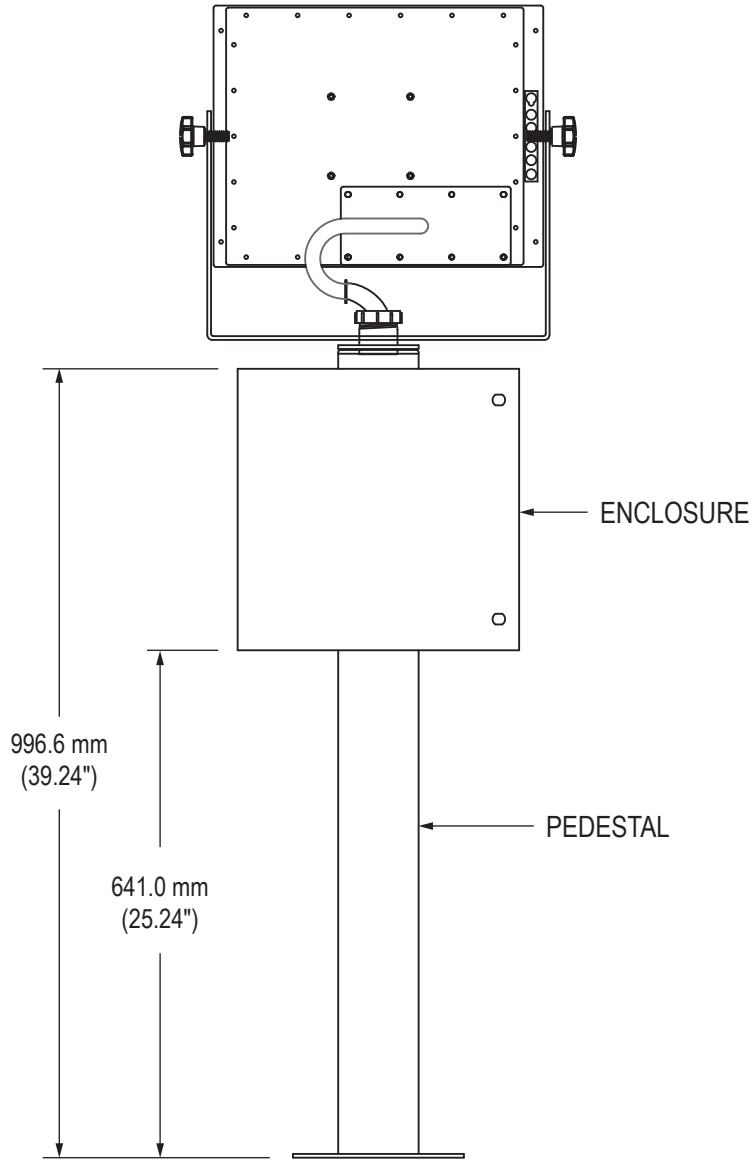

Side View

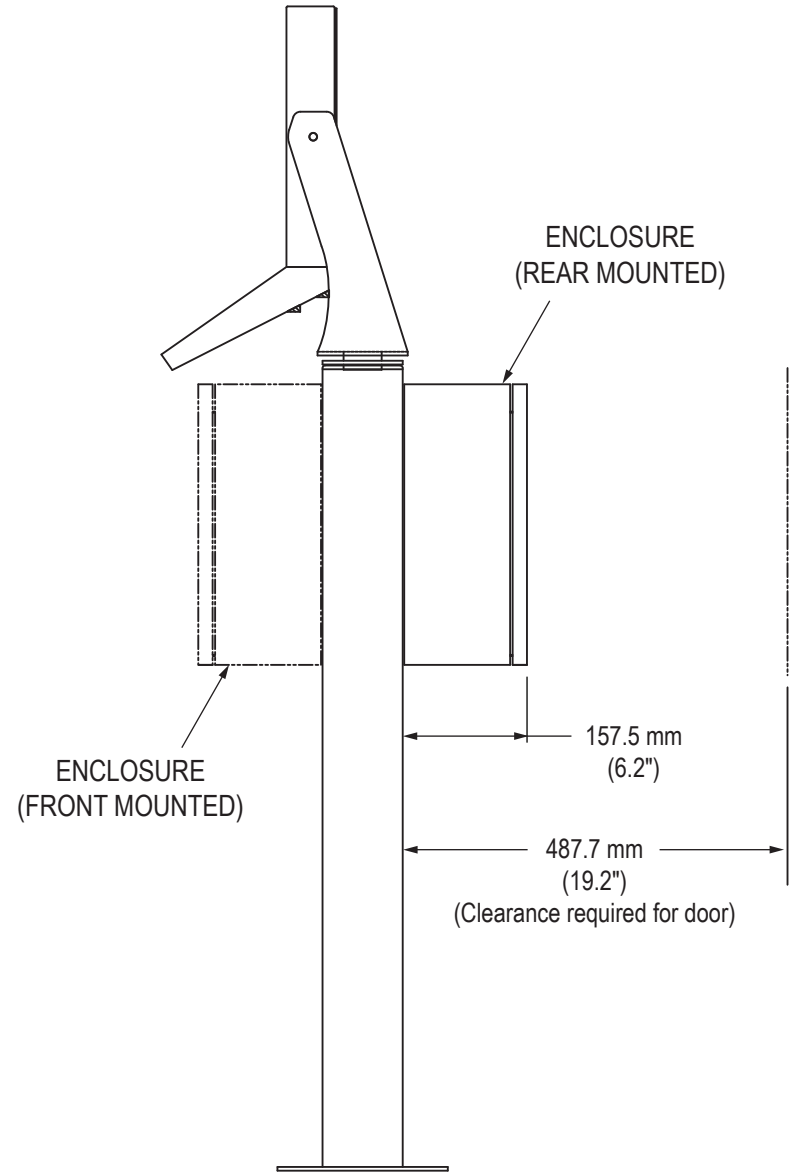

Mechanical Drawing – Thin Client / Small PC Enclosure

