



# Installation Instructions

## KB-M2-P90, KB-R2-P90, and KB-R3-P90 Series Flat Panel Mount Keyboards

1. Cut mounting pattern in panel. Refer to Figure 1 for the cutout dimensions.

**NOTE: The maximum panel thickness allowed for the keyboard is 6.0 mm (1/4").**

2. Remove and set aside the 16 locknuts from the rear of the keyboard, then temporarily remove the rear collar from the keyboard.
3. Insert the keyboard into the panel and reattach the collar.
4. Tighten all 16 locknuts until the gasket is compressed to 1/16" to 3/32" thick.

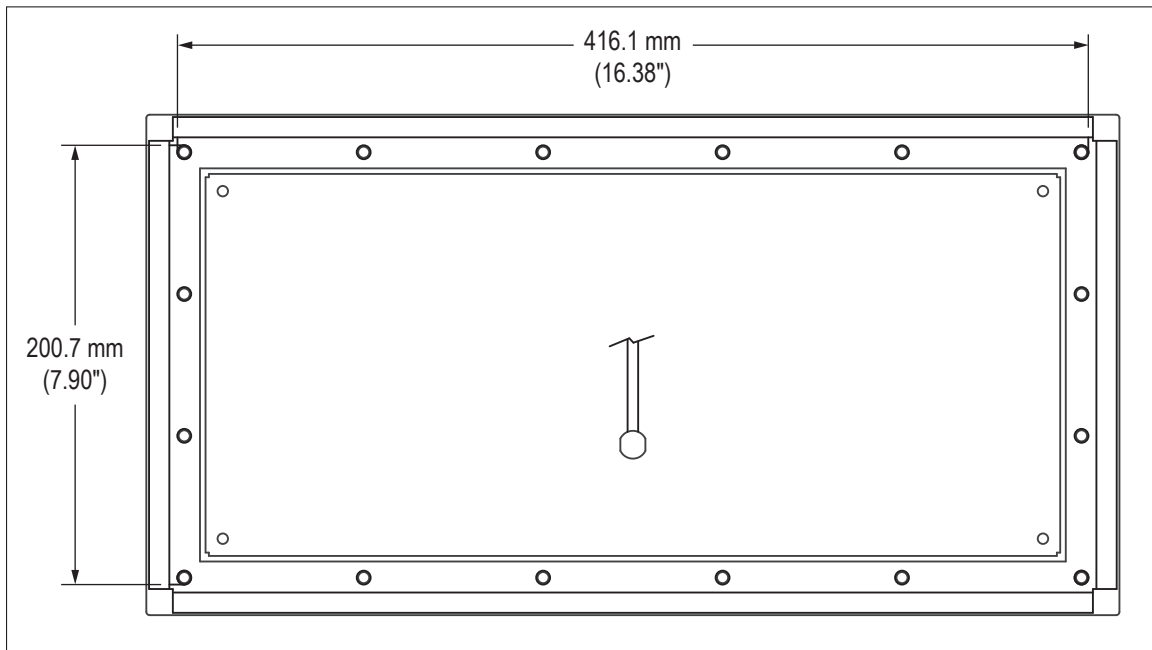

FIGURE 1 – REAR VIEW SHOWING CUTOUT DIMENSIONS

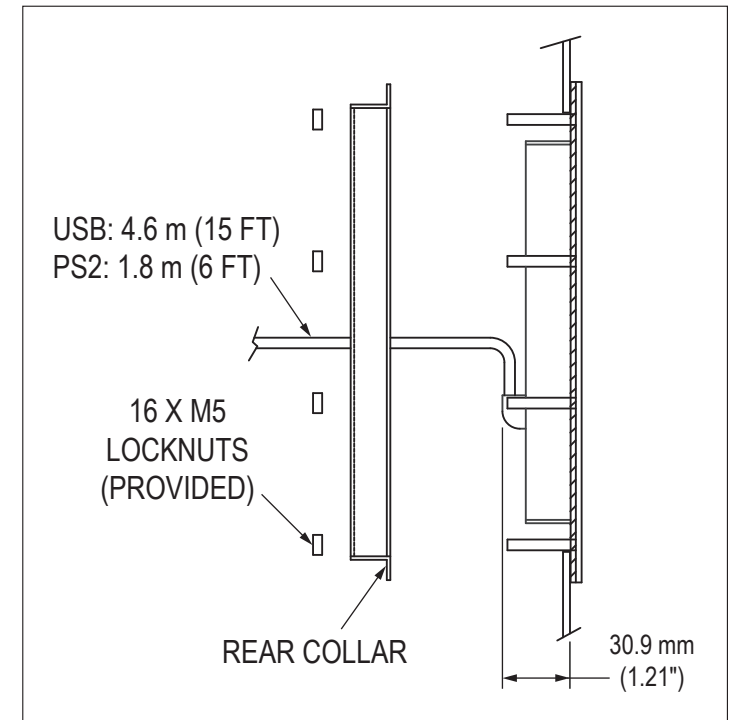

FIGURE 2 – SIDE VIEW