

15/17" MODEL

Side View

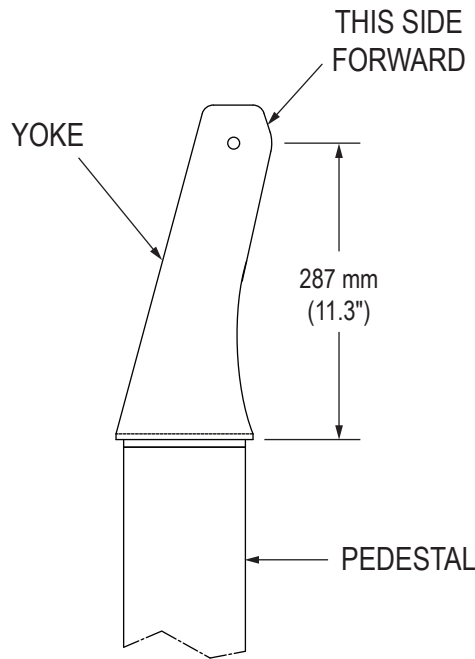

Front View

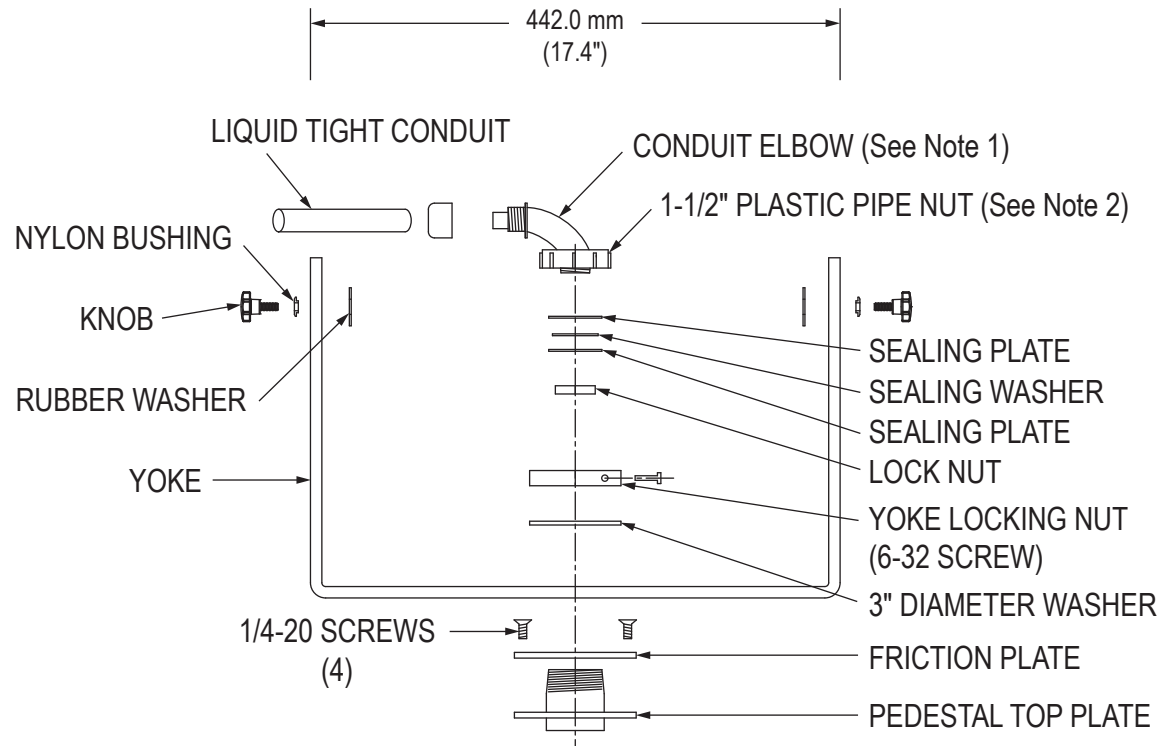

Pedestal Plate (in bottom of Pedestal for hidden cable access)

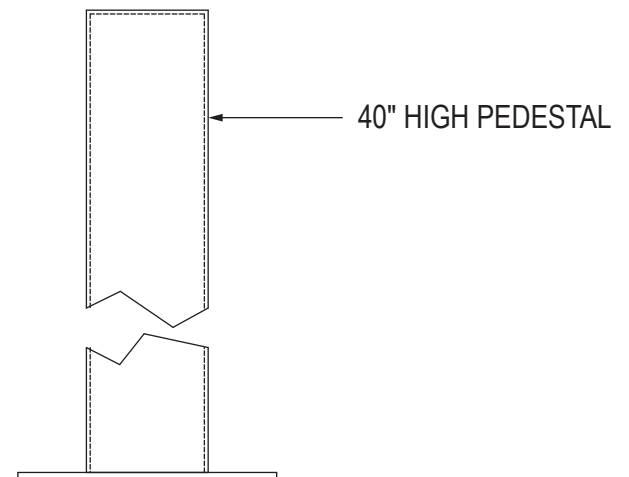
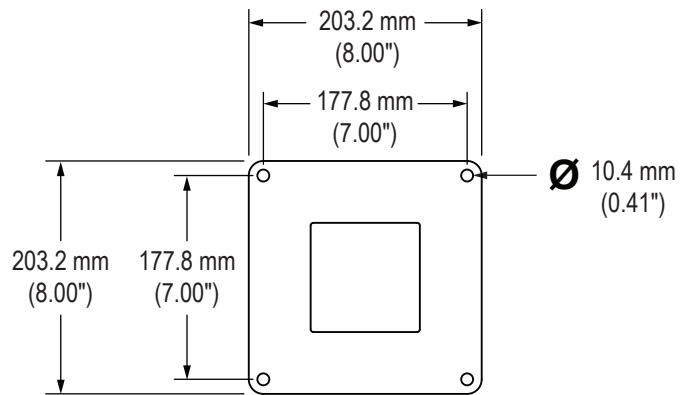

Mechanical Drawing – Yoke and Pedestal Mount

© 2017



Hope Industrial Systems, Inc.

Toll Free: (877) 762-9790 · International: +1 (678) 762-9790
 UK: +44 (0) 20 7193-2618 · E-mail: support@HopeIndustrial.com

Part Number: PED4X4 series

Revision:

Date: 2016.01.29

Page 1 of 9

NOTES: 1) Position Conduit Elbow as shown for freedom of movement of Flexible Conduit.
 2) Tighten Plastic Pipe Nut after positioning Conduit Elbow.

19" MODEL

Side View

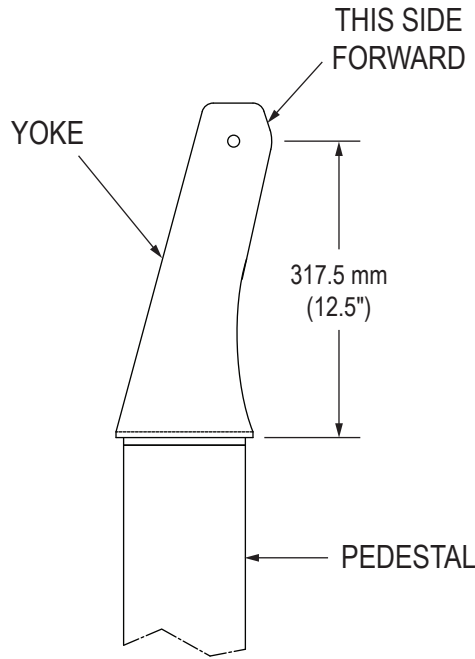

Front View

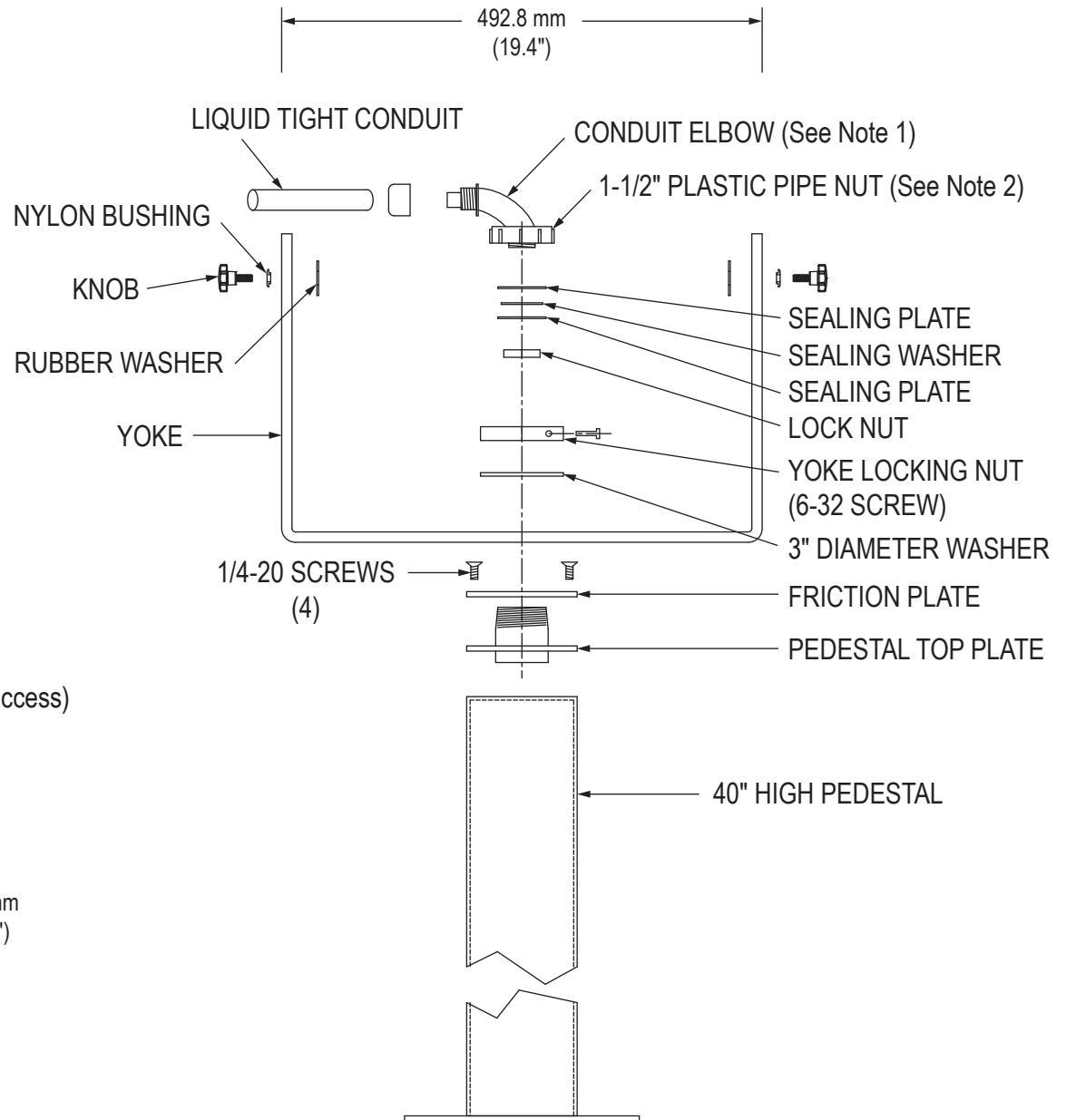

Pedestal Plate (in bottom of Pedestal for hidden cable access)

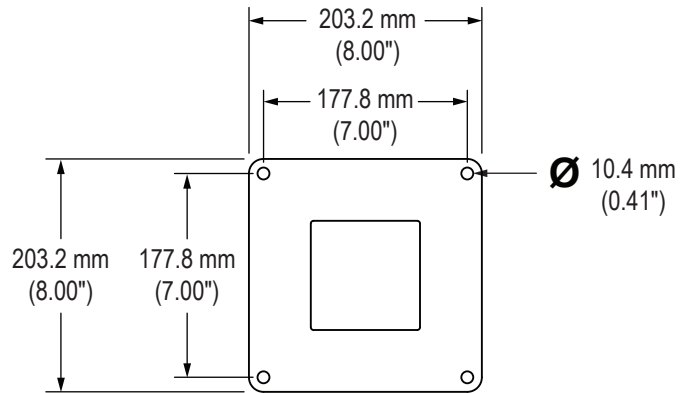

19.5" MODEL

Side View

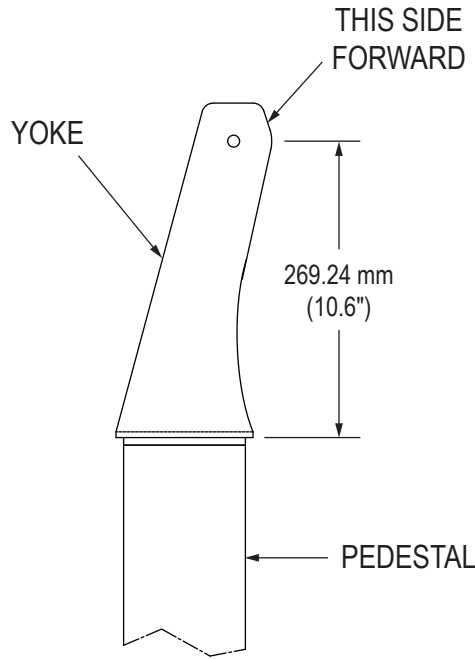

Front View

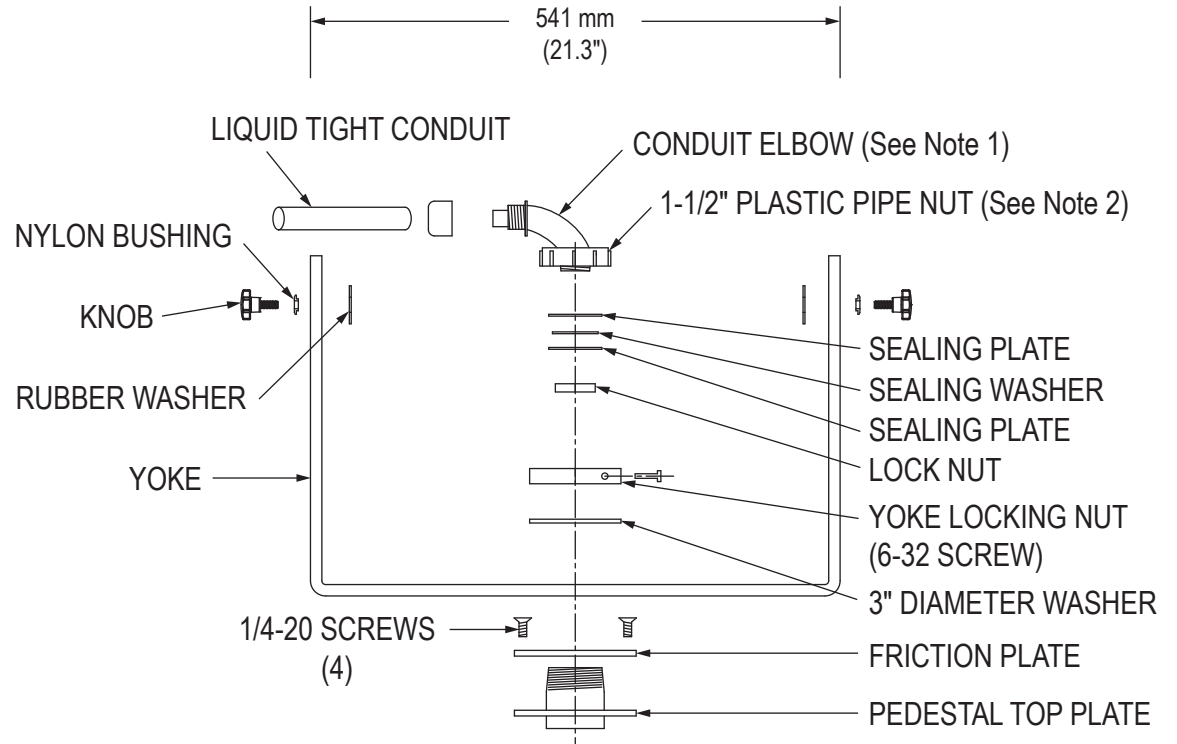

Pedestal Plate (in bottom of Pedestal for hidden cable access)

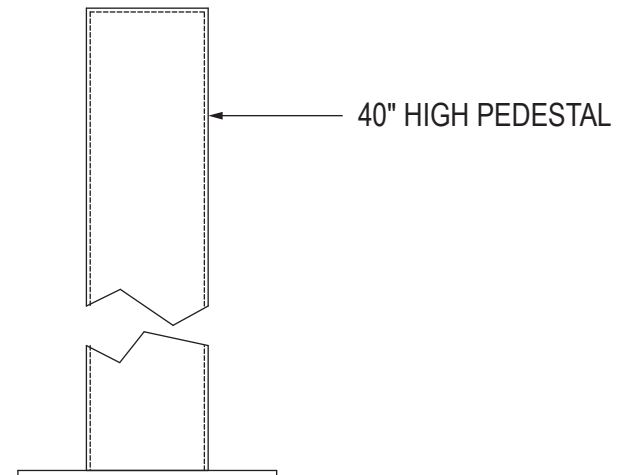
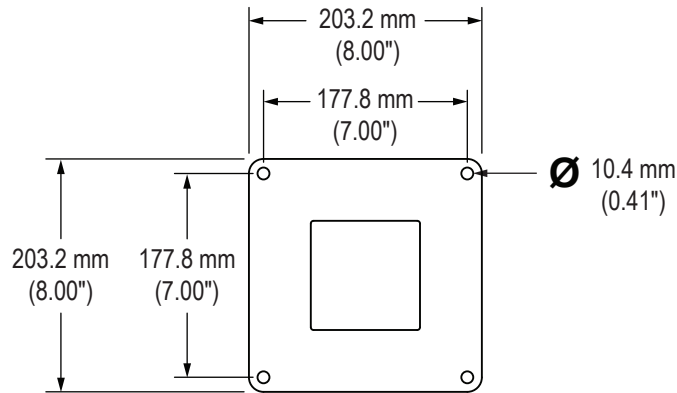

22" MODEL

Side View

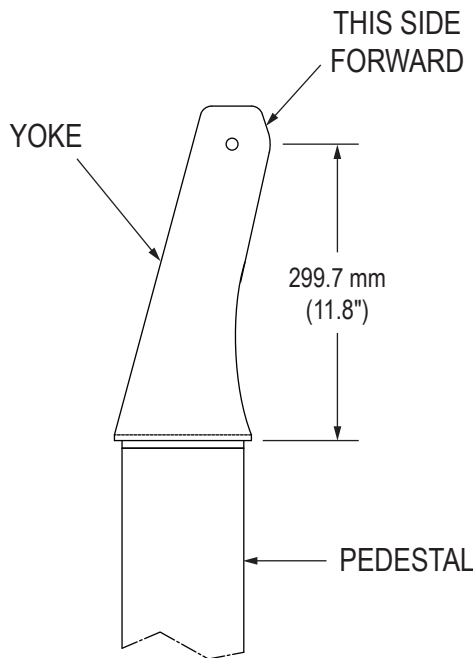

Front View

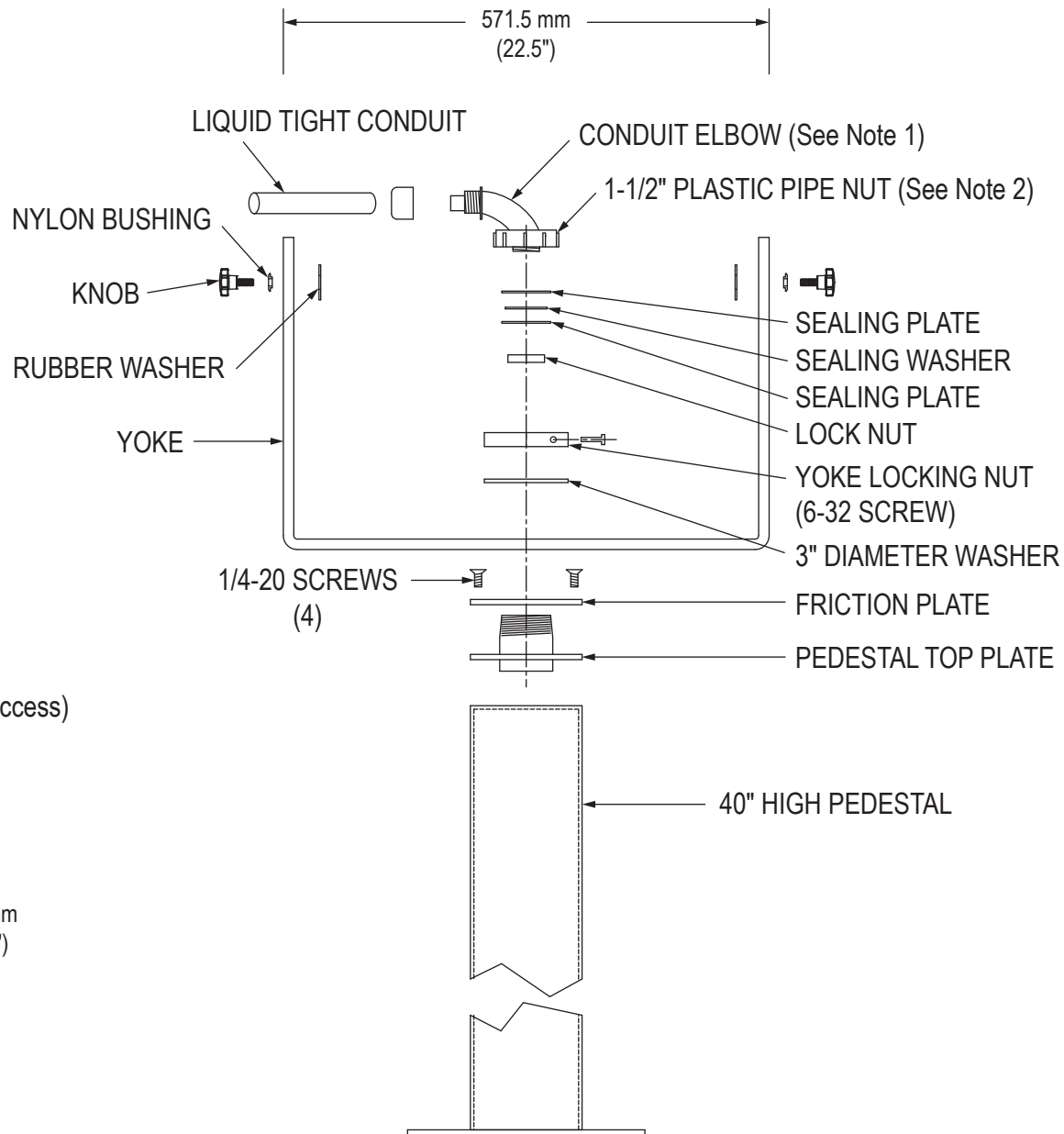

Pedestal Plate (in bottom of Pedestal for hidden cable access)

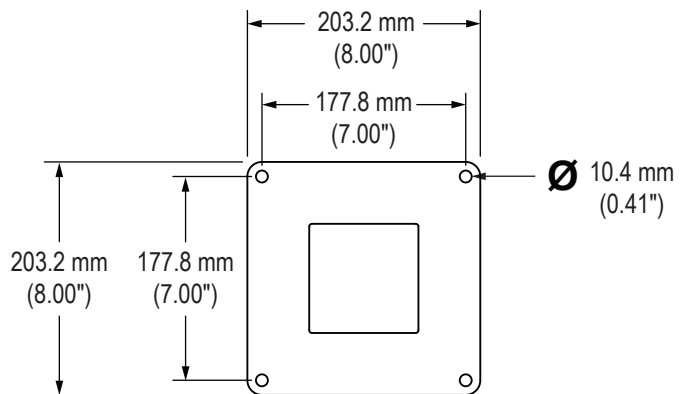

Mechanical Drawing – Yoke and Pedestal Mount



23" MODEL

Side View

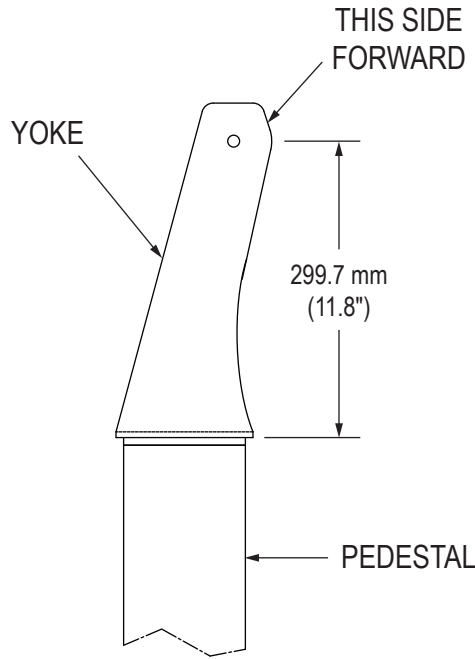

Front View

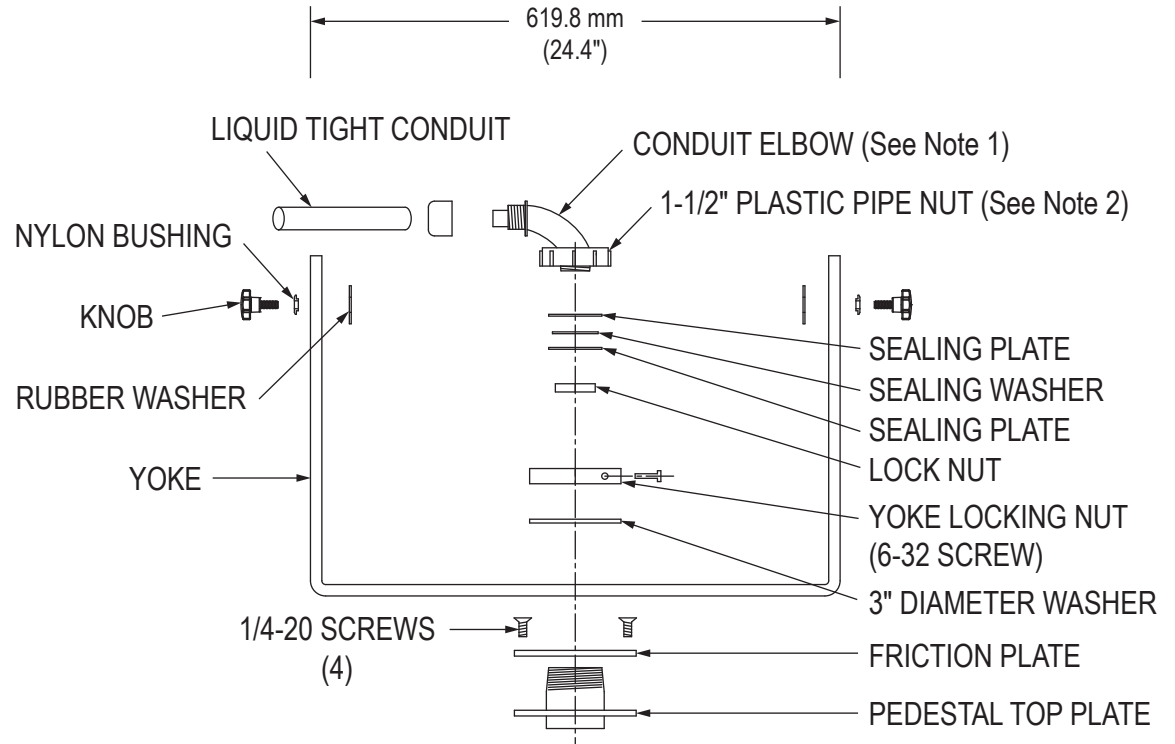

Pedestal Plate (in bottom of Pedestal for hidden cable access)

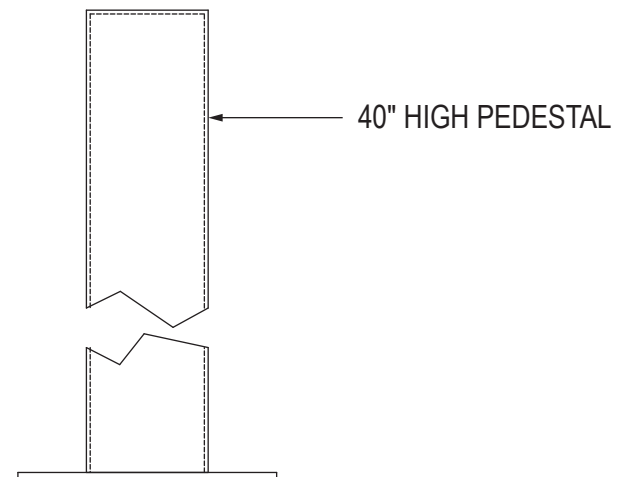
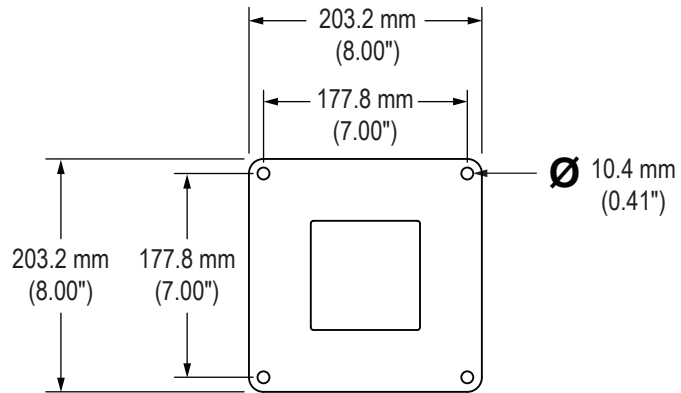

Mechanical Drawing – Yoke and Pedestal Mount

© 2017



Hope Industrial Systems, Inc.

Toll Free: (877) 762-9790 · International: +1 (678) 762-9790
 UK: +44 (0) 20 7193-2618 · E-mail: support@HopeIndustrial.com

Part Number: PED4X4 series

Revision:

Date: 2016.01.29

Page 5 of 9

NOTES: 1) Position Conduit Elbow as shown for freedom of movement of Flexible Conduit.
 2) Tighten Plastic Pipe Nut after positioning Conduit Elbow.

MOBL4X4-CSTR-XX FLOOR STAND (OPTIONAL)

Full Workstation

- 287 mm (11.3") for YB1517
- 317.5 mm (12.5") for YB19
- 269.24 mm (10.6") for YB19.5
- 299.7 mm (11.8") for YB22
- 299.7 mm (11.8") for YB23

1016 mm
(40.00")

101.3 mm (4.0")
(Extra height created
by caster wheels)

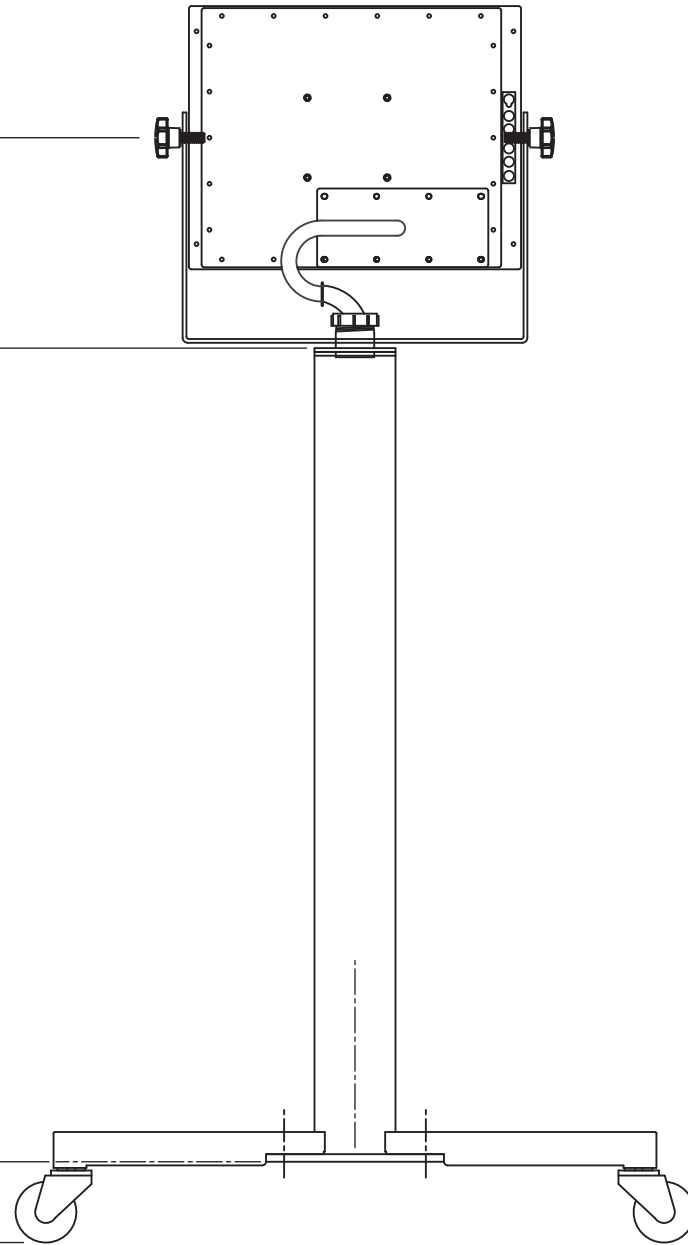

MOBL4X4-CSTR-XX FLOOR STAND (OPTIONAL)

Top View

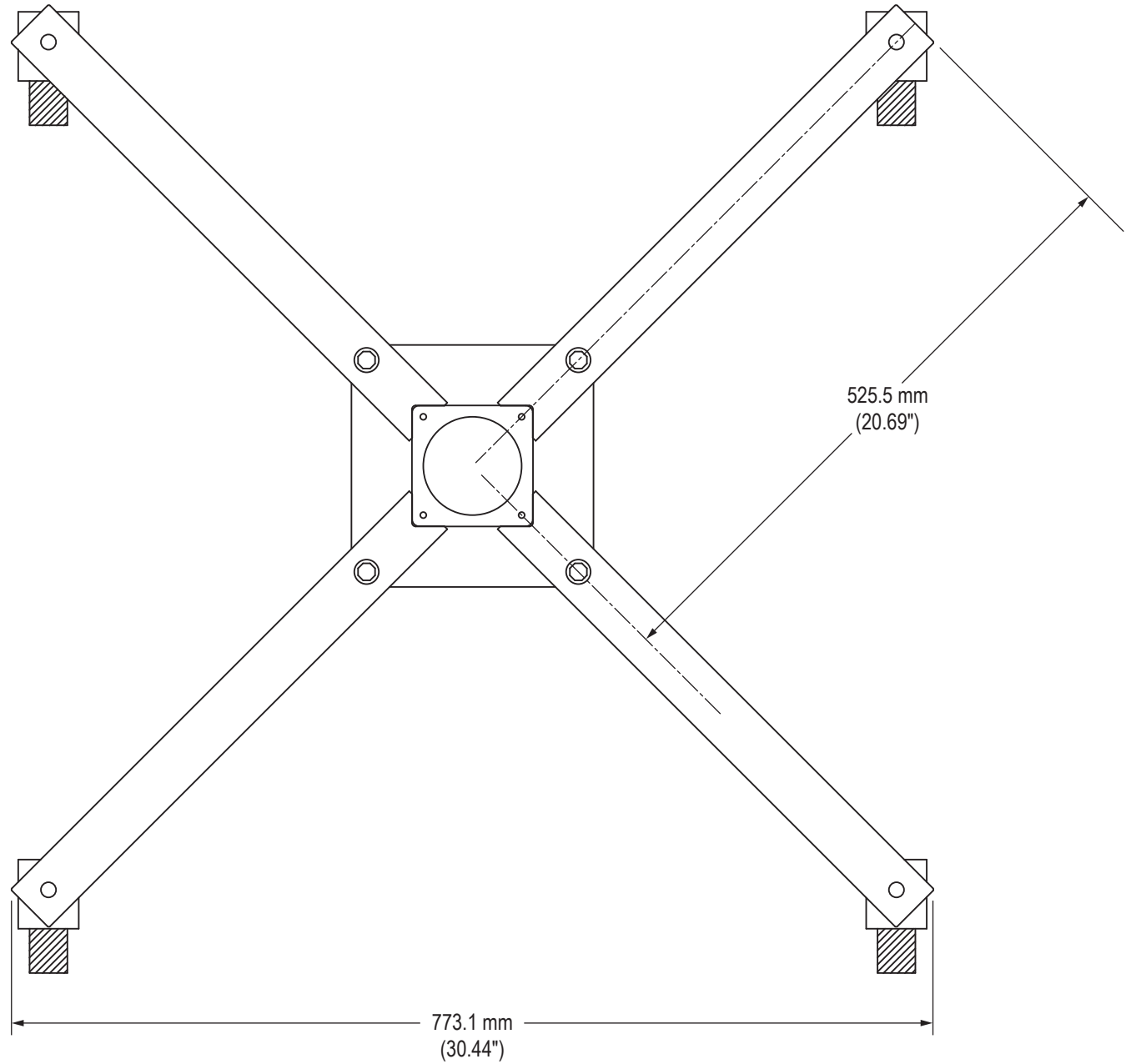

Mechanical Drawing – Yoke and Pedestal Mount

© 2017



Hope Industrial Systems, Inc.
 Toll Free: (877) 762-9790 · International: +1 (678) 762-9790
 UK: +44 (0) 20 7193-2618 · E-mail: support@HopeIndustrial.com

Part Number: PED4X4 series
 Date: 2016.01.29
 Revision:
 Page 7 of 9

NOTES: 1) Position Conduit Elbow as shown for freedom of movement of Flexible Conduit.
 2) Tighten Plastic Pipe Nut after positioning Conduit Elbow.

MOBL4X4-FIXD-XX FLOOR STAND (OPTIONAL)

Full Workstation

- 287 mm (11.3") for YB1517
- 317.5 mm (12.5") for YB19
- 269.24 mm (10.6") for YB19.5
- 299.7 mm (11.8") for YB22
- 299.7 mm (11.8") for YB23

1016 mm
(40.00")

38 mm to 64 mm (1.5" to 2.5")
(Extra height created by feet)

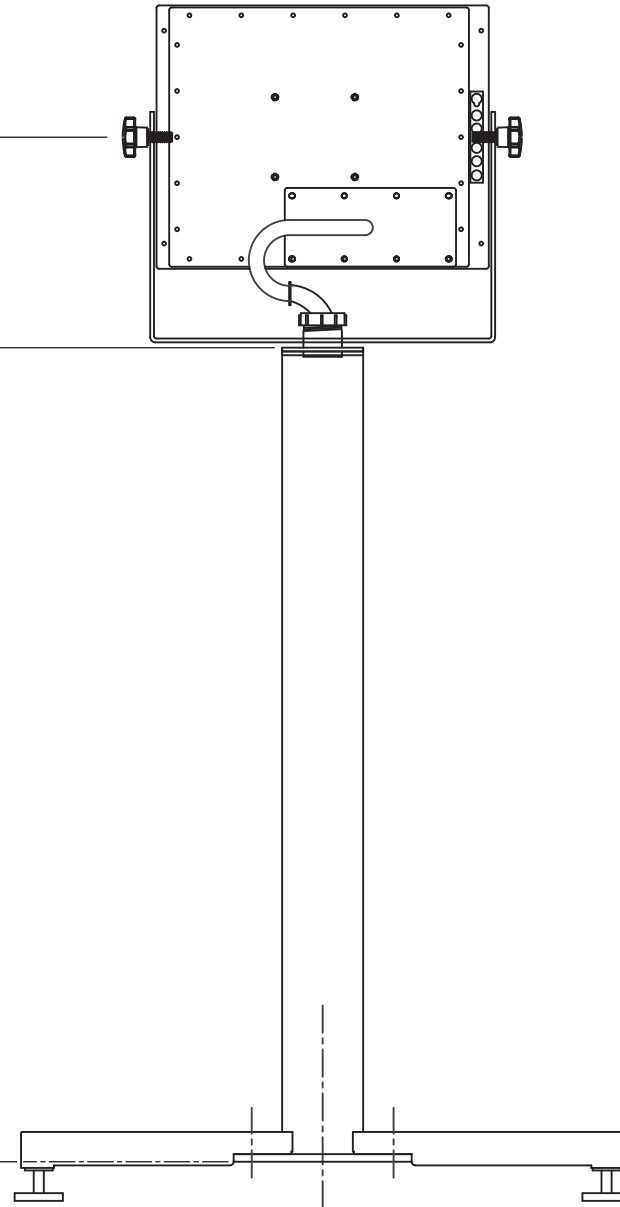

Mechanical Drawing – Yoke and Pedestal Mount

© 2017



Hope Industrial Systems, Inc.

Toll Free: (877) 762-9790 · International: +1 (678) 762-9790
UK: +44 (0) 20 7193-2618 · E-mail: support@HopelIndustrial.com

Part Number: PED4X4 series

Revision:

Date: 2016.01.29

Page 8 of 9

NOTES: 1) Position Conduit Elbow as shown for freedom of movement of Flexible Conduit.
2) Tighten Plastic Pipe Nut after positioning Conduit Elbow.

MOBL4X4-FIXD-XX FLOOR STAND (OPTIONAL)

Top View

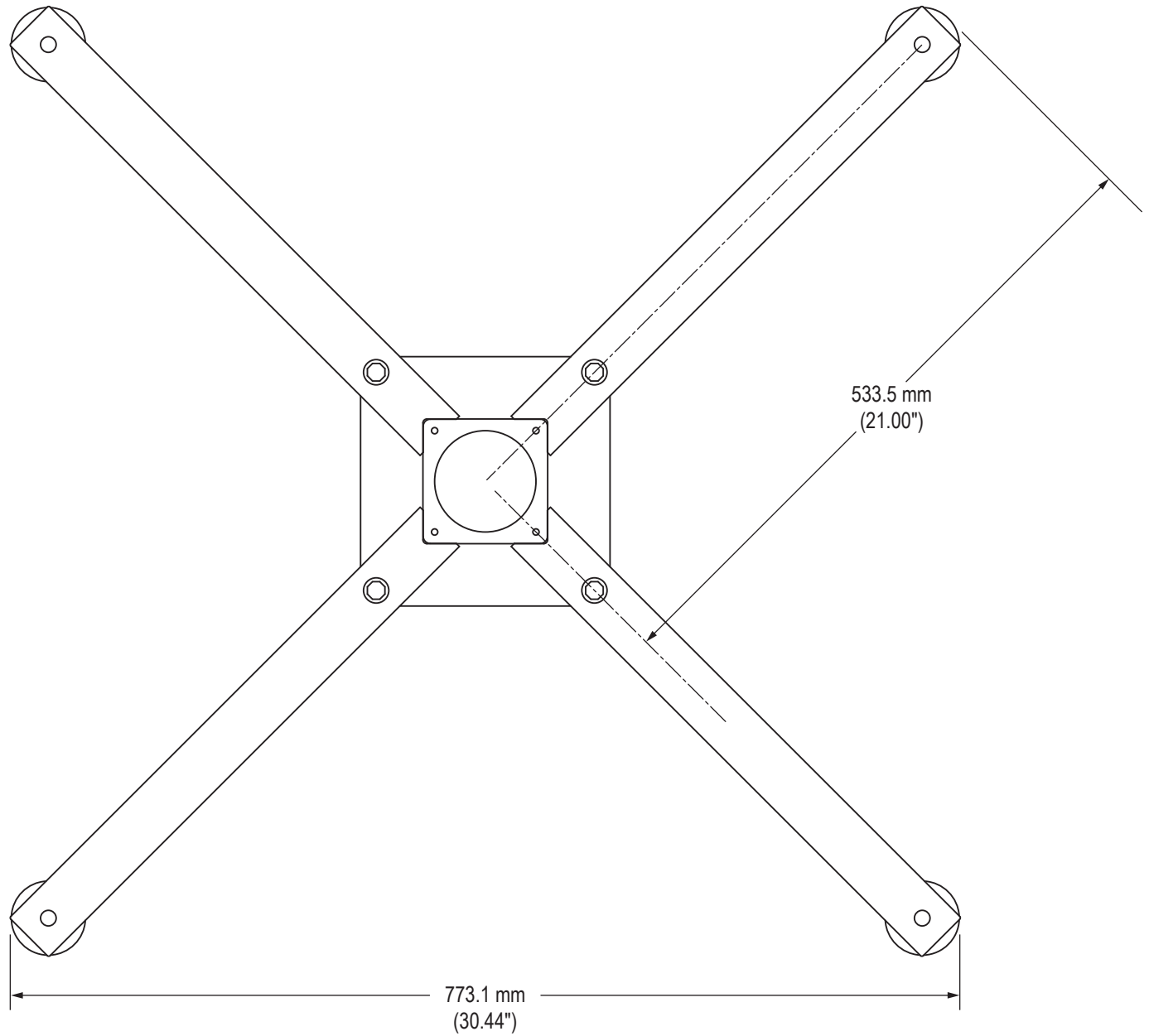

Mechanical Drawing – Yoke and Pedestal Mount

© 2017



Hope Industrial Systems, Inc.
Toll Free: (877) 762-9790 · International: +1 (678) 762-9790
UK: +44 (0) 20 7193-2618 · E-mail: support@HopeIndustrial.com

Part Number: PED4X4 series
Revision:

Date: 2016.01.29
Page 9 of 9

NOTES: 1) Position Conduit Elbow as shown for freedom of movement of Flexible Conduit.
2) Tighten Plastic Pipe Nut after positioning Conduit Elbow.