

Front View

Side View

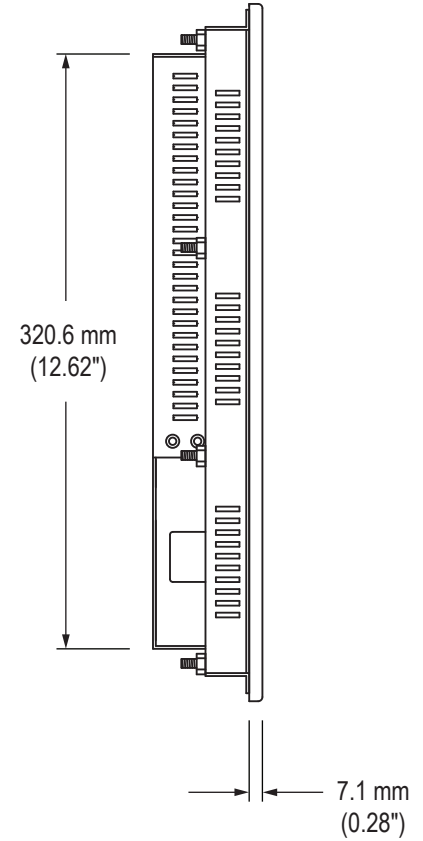

Rear View (showing Cutout Dimensions)

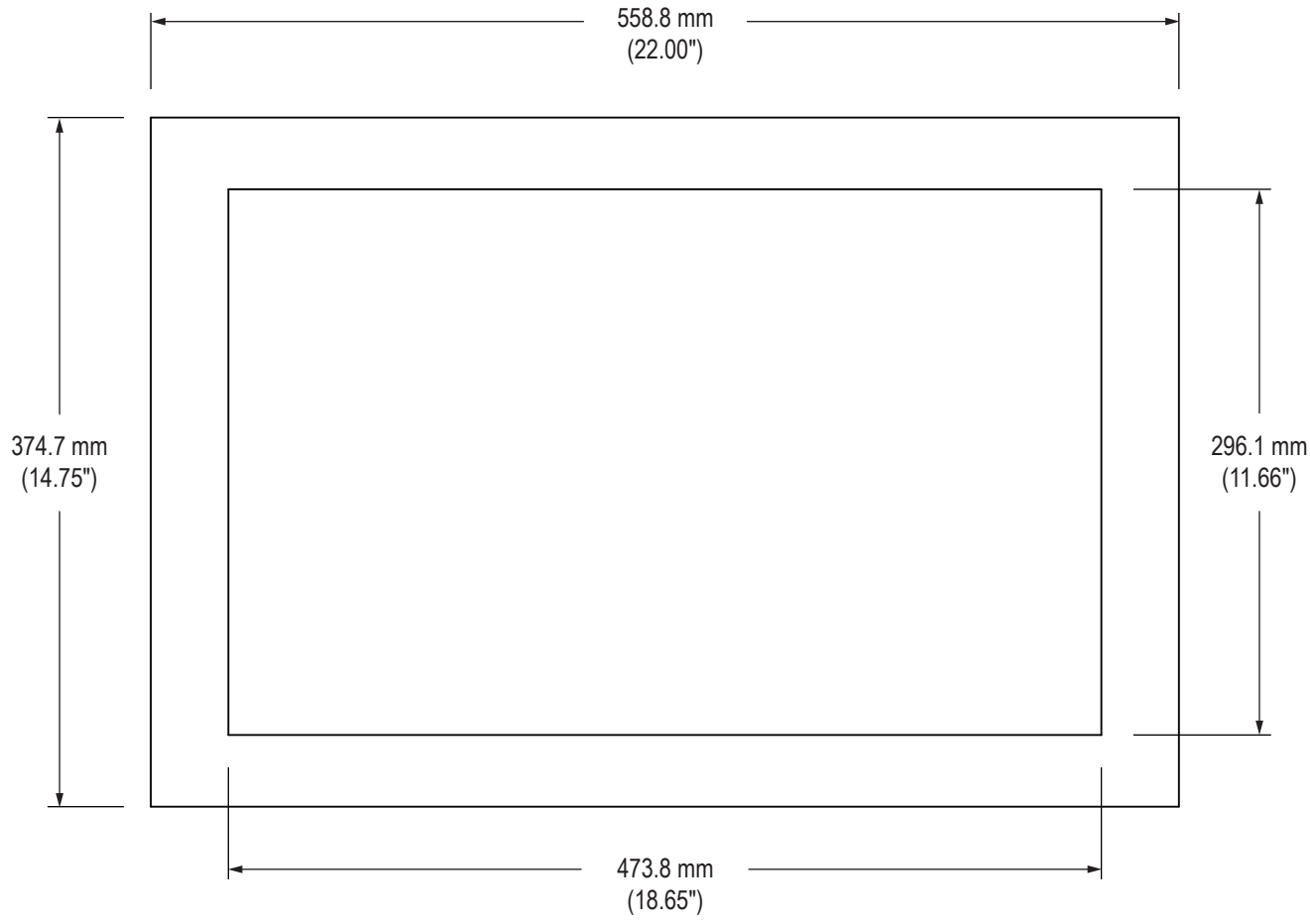
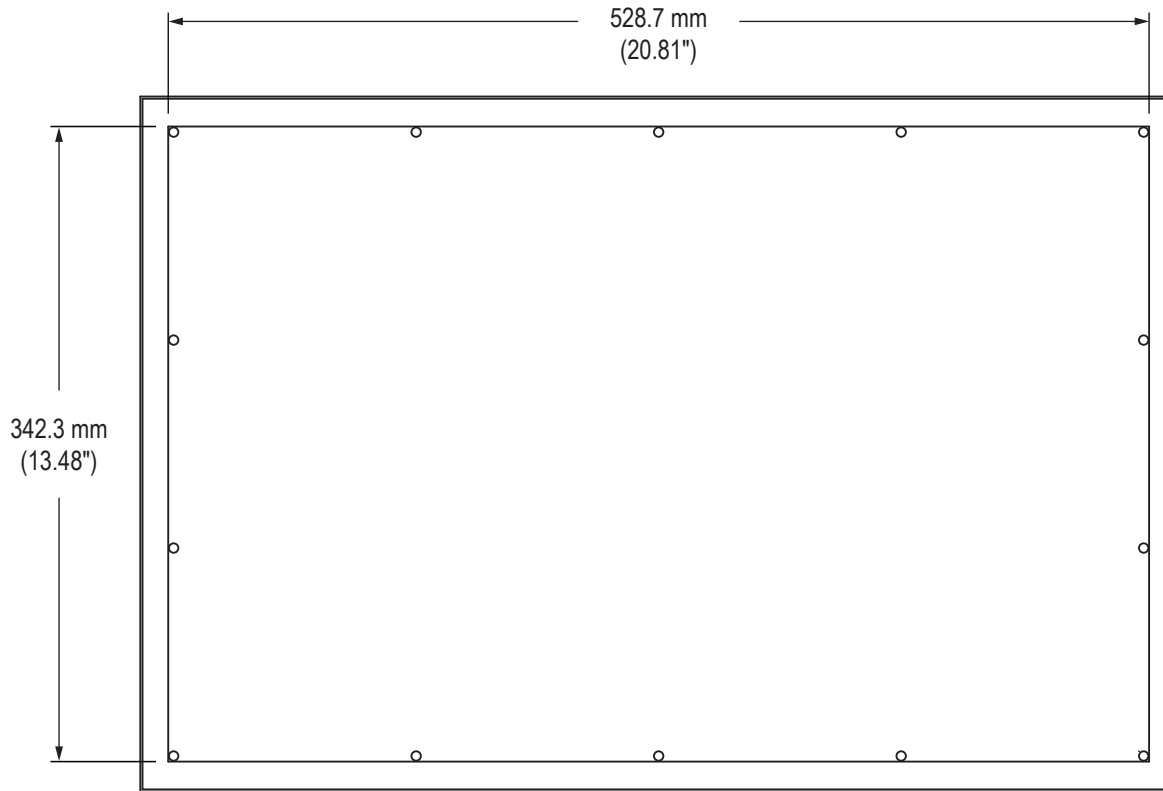

Bottom View

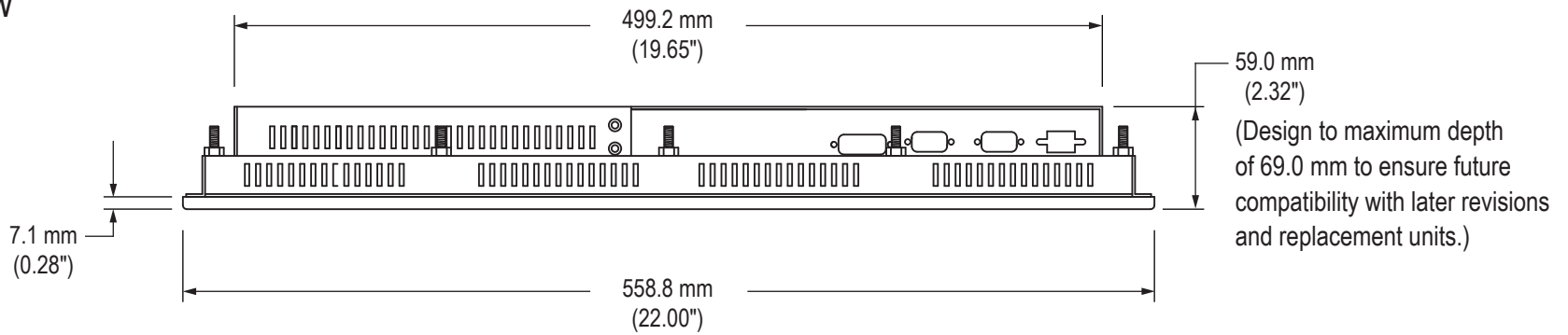

Cable Connections

Rear View

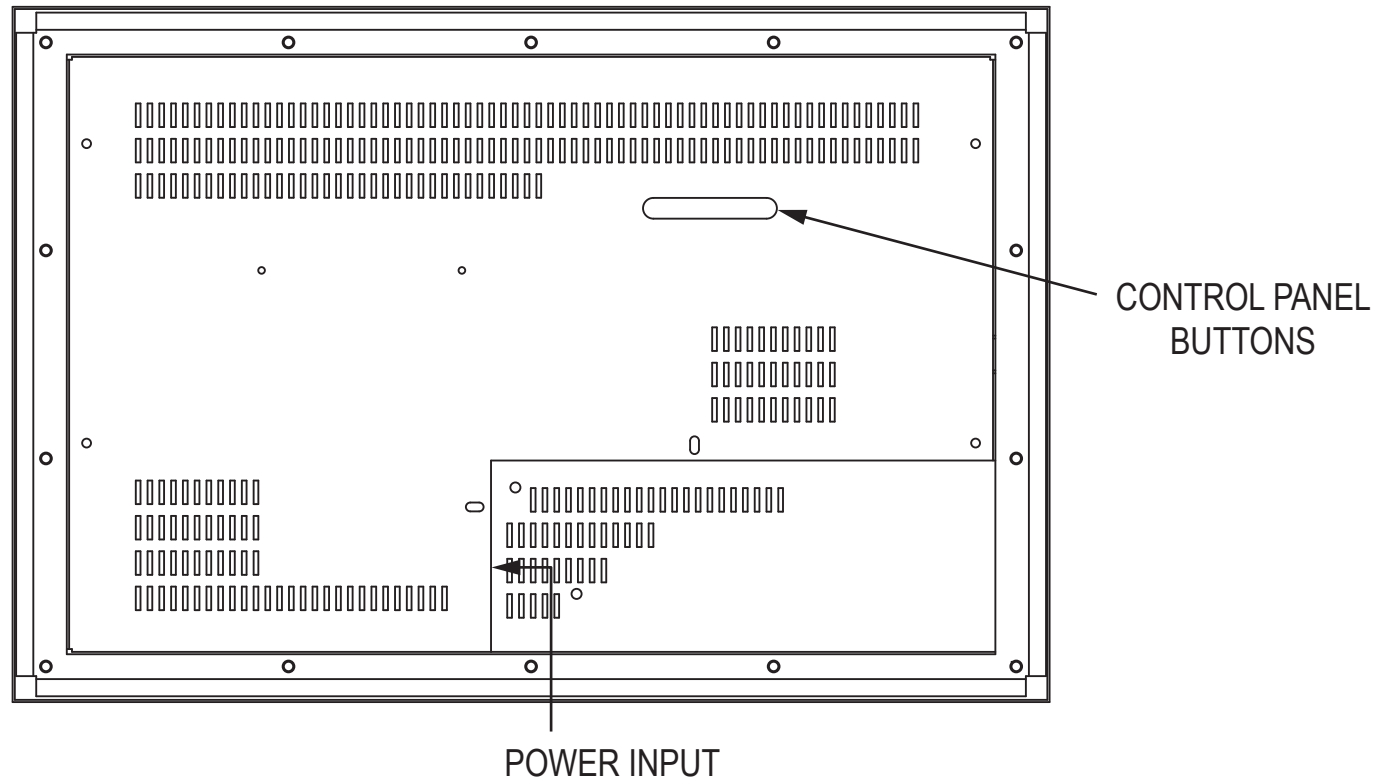

Bottom View

