

Front View

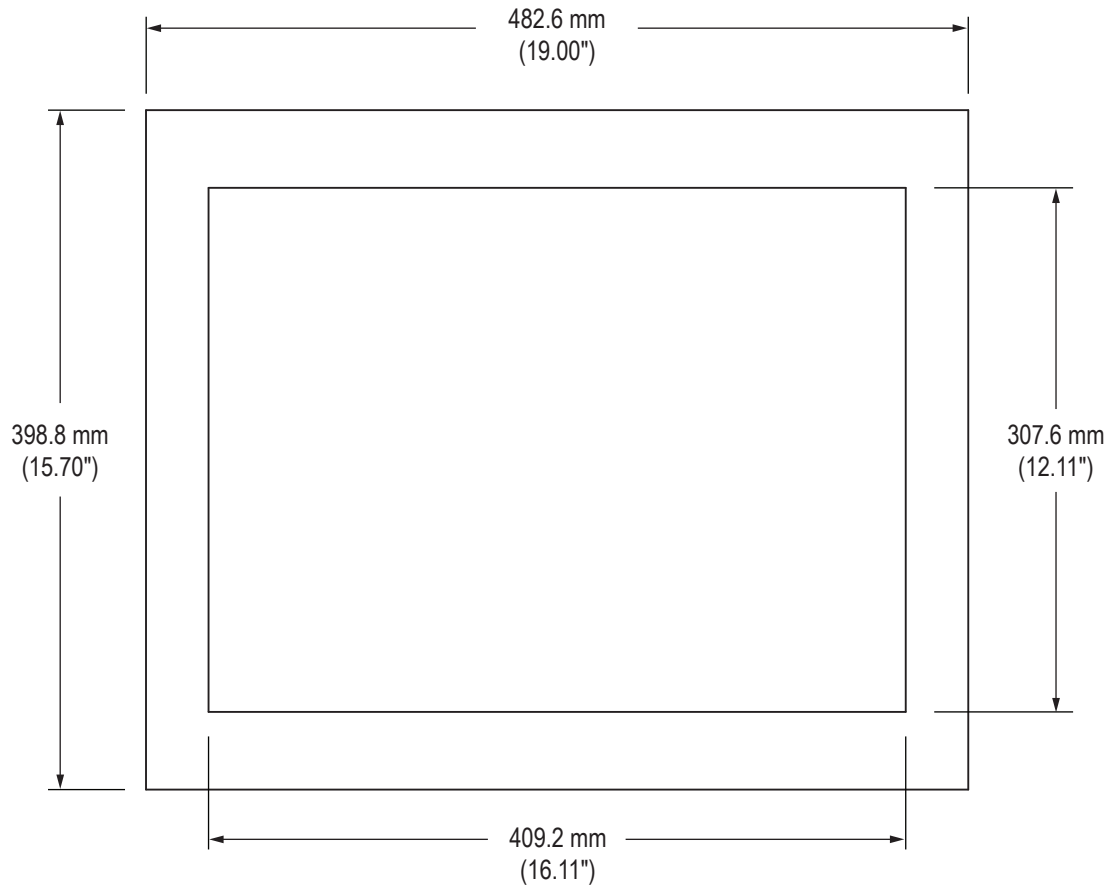

Side View

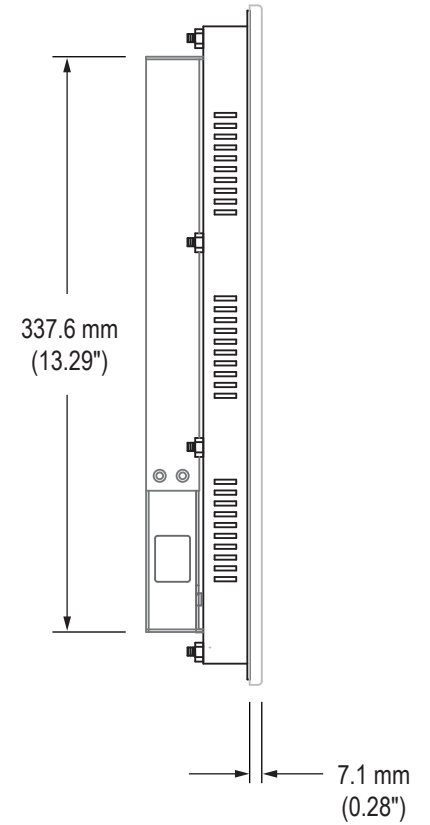

### Rear View (showing Cutout Dimensions)

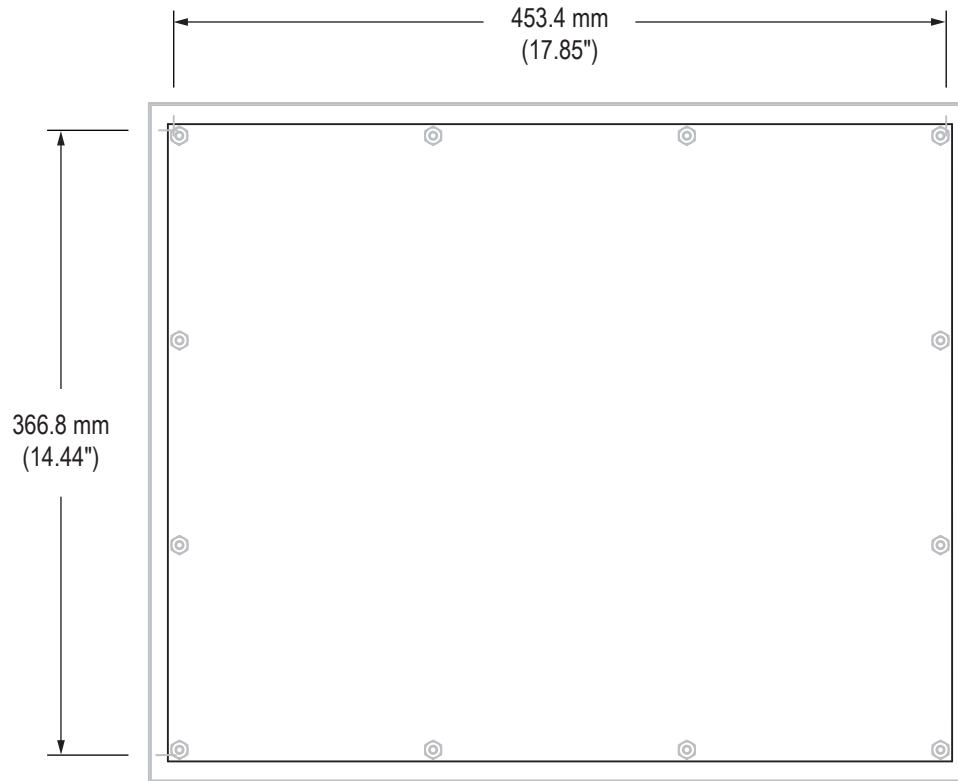

### Bottom View

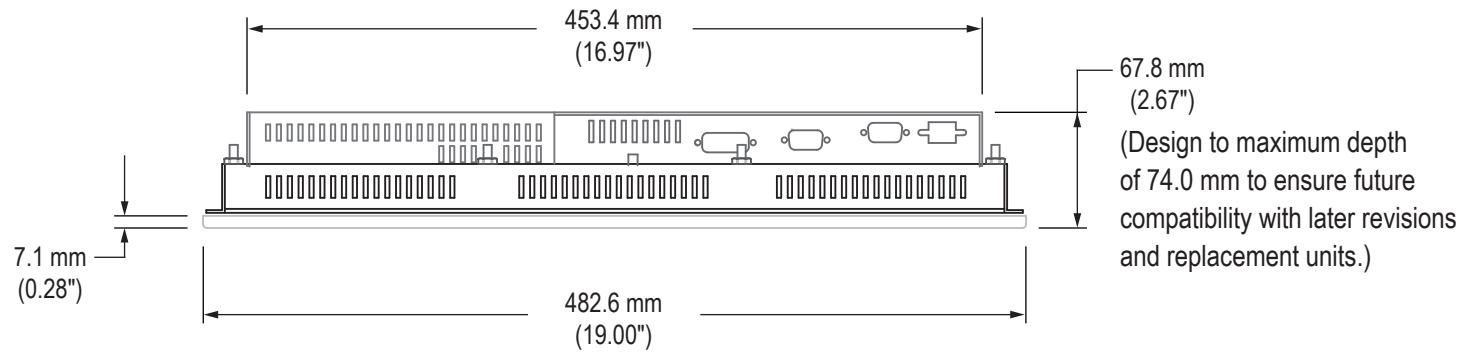

# Cable Connections

## Rear View

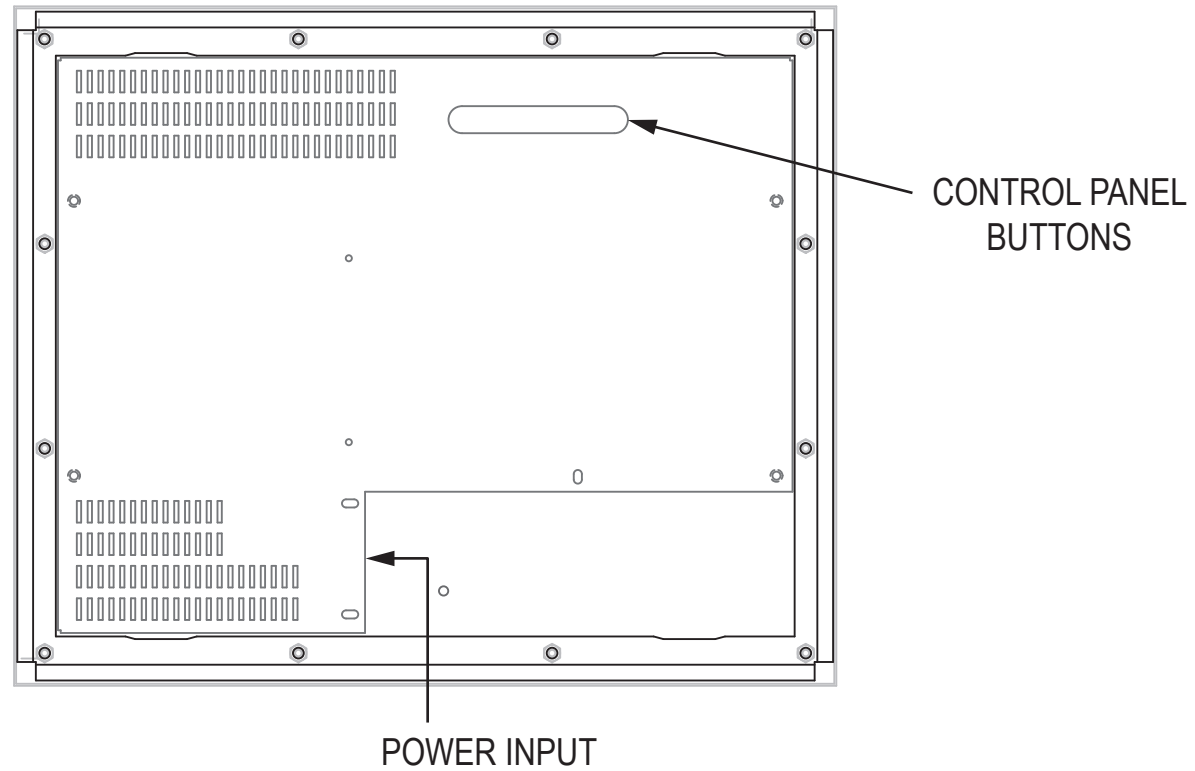

## Bottom View

